

REVISIONS		
REV	DESCRIPTION	DATE
-	RELEASED	040215

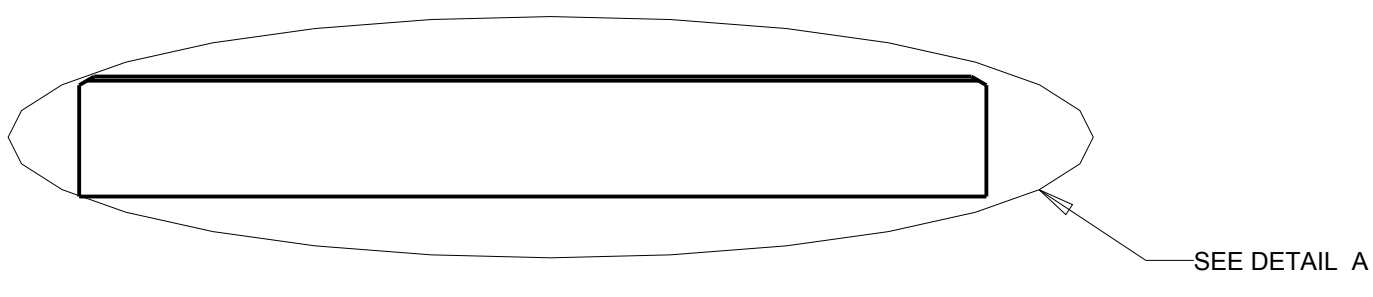
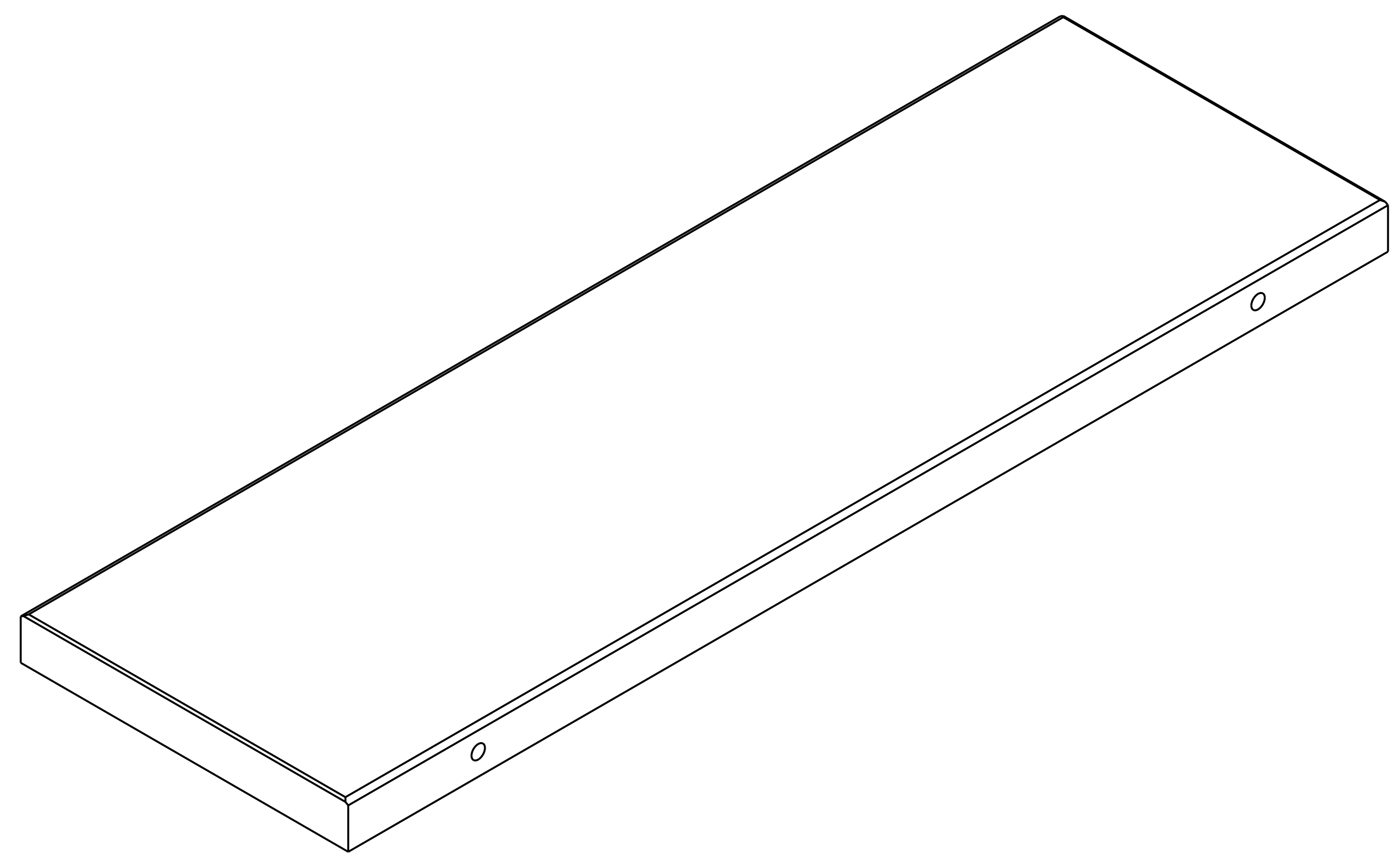
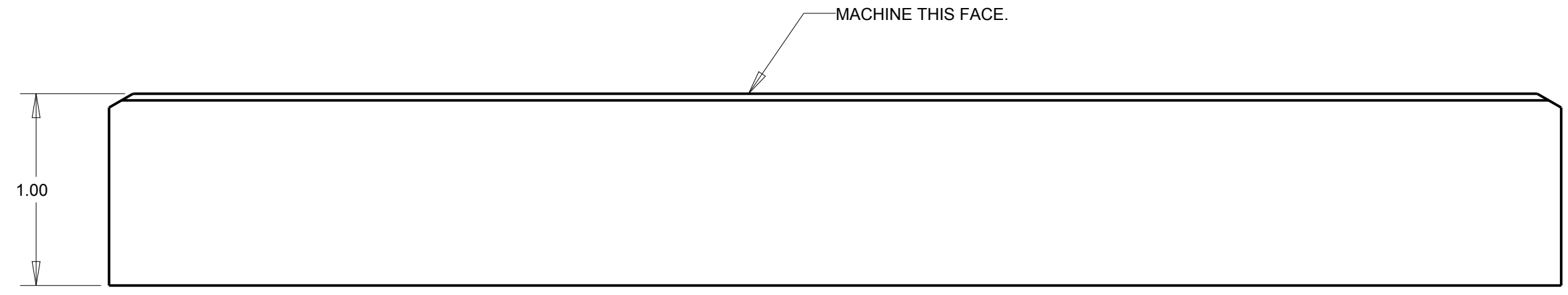
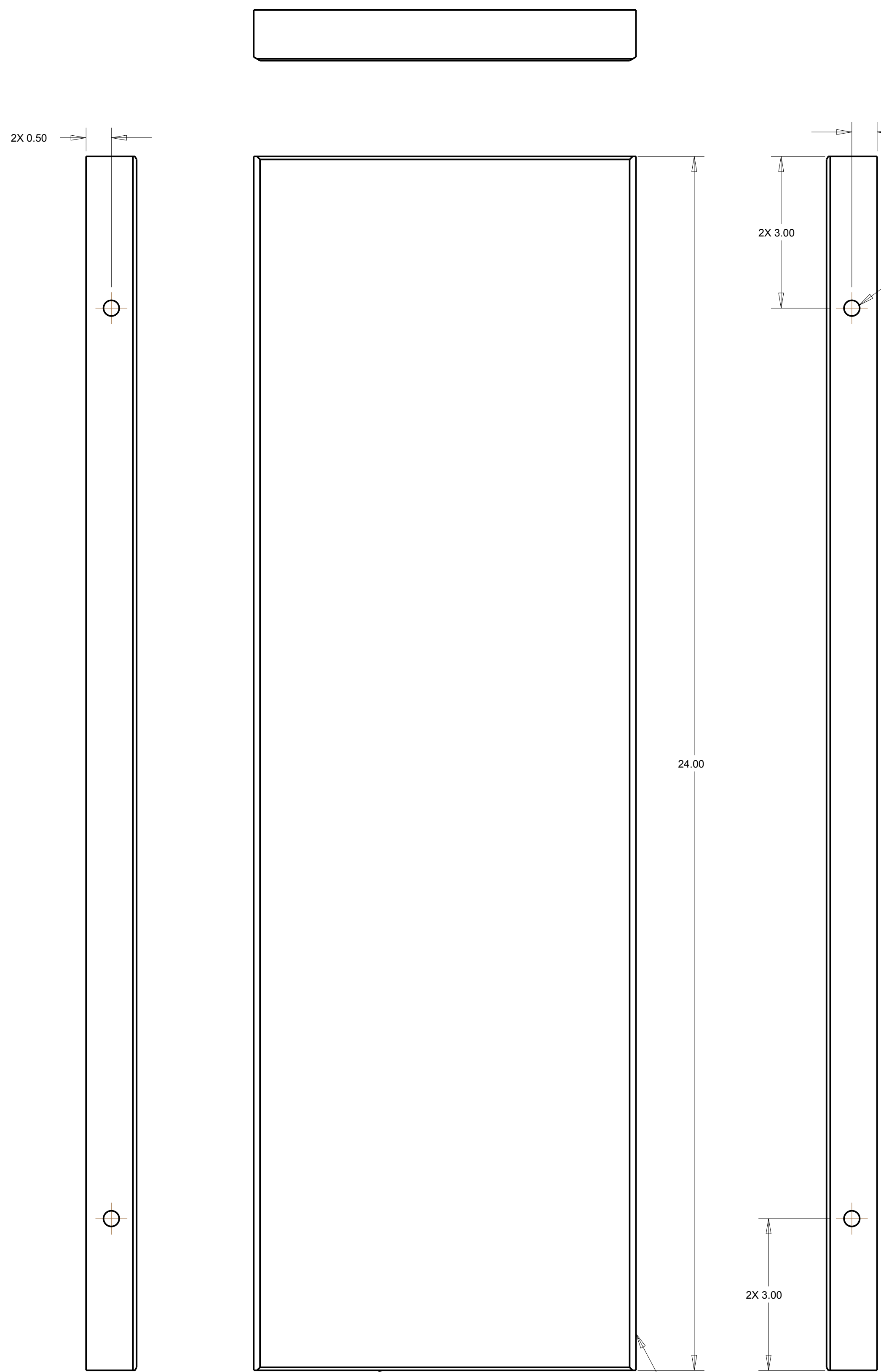

DETAIL A SCALE 1.500

SS304_316		MATERIAL SPECIFICATION	
THIRD ANGLE PROJECTION	DIMENSIONS ARE IN INCHES DUAL DIMENSIONING IS NOTED AS: INCH [MM] OR INCH [MM]	7950 Corporate Blvd. Plain City, Ohio 43064	
	TOLERANCES ARE: DECIMALS .X ±.03 [ .76] .XX ±.01 [ .25] .XXX ±.004 [ .101]	TITLE <b>FTR WAVEFORM (WELDED) LOAD TEST TOP PLATE</b>	
CONFIDENTIAL INFORMATION OF VELOCYS, INC.		DETAIL DESIGNER	SIZE <b>D</b>
DATE Feb-02-15		DATE	DWG. NO. 1006309
SCALE 0.625		SCALE	SHEET 1 OF 1

BACKGROUND TECHNOLOGY

DRW: 1006309  
PART: 1006309